



Focus on

- 1 electric motor for height adjustments
- Mattress complete with zak headrest
- Gas spring for backrest adjustment
- Adjustable legrest with 5 different angles
- An ideal solution for multirooms
- Maximum client/practitioner comfort

Focus on

- 1 motore elettrico per sollevamento della base
- Materasso completo di testa zak estraibile
- Schienale regolabile mediante molla a gas
- Gambe regolabili con 5 diverse inclinazioni
- Ideale per cabine multifunzionali
- Massimo comfort cliente/operatore

Dimensions / Dimensioni

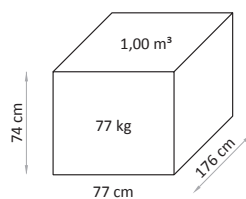
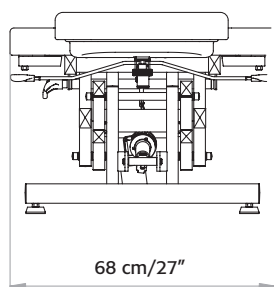
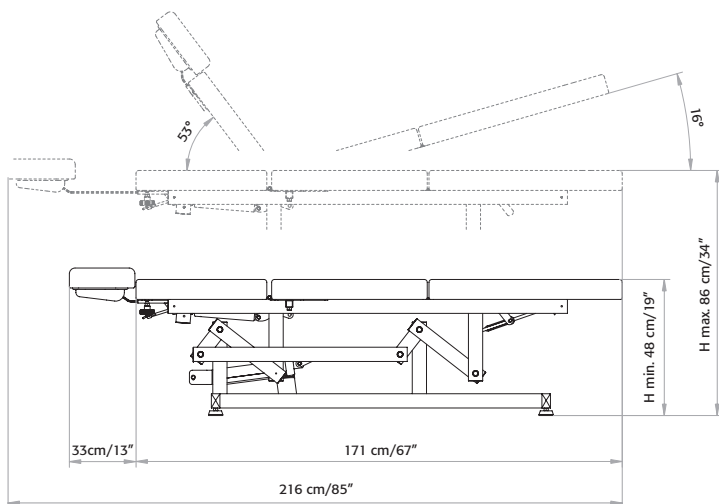

Finishing / Finiture



- Bianco / White
- Beige
- Grigio / Grey



NEFOS COLORS

COLORI NEFOS

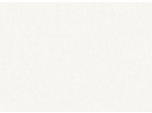

6



1155



1182

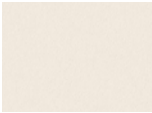

1957



6985



3962



2124

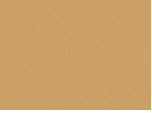

2146



1194

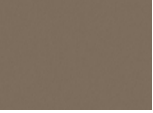

6986



64



71



2173



1388



667



680



569



1843



1868



6942



6941



5946



6940



4942



1305

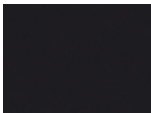

991

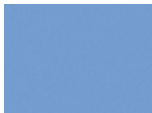

8009

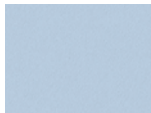

8019

ACCESSORIES UPON REQUEST



cod. 076
Armrest couple
Coppia braccioli



cod. 114 P
Mattress protection with polyurethane
Coprilettino con poliuretano



cod. 126
Luxury cover towel
Telo deluxe



cod. 108 VR / cod. 108 VR XL
Roll holder (66/75 cm)
Portarotolo



cod. LEM-139 R
Wheels with brake (ø 50 mm)
Ruote con freno (ø 50 mm)

ACCESSORI SU RICHIESTA



cod. 068
Face hole headrest
Testa ad asola



cod. 183
American headrest
Testa americana



cod. 118
Paper roll
Rotolo di carta



cod. PROT. GAMBE
Leg cover
Proteggi gambe



cod. LOGO
Customized mattress with logo
Personalizzazione materasso con logo

	<i>voltage</i> voltaggio	<i>frequency</i> frequenza	<i>absorption</i> assorbimento	<i>transformer</i> trasformatore	<i>protection rating</i> grado di protezione	<i>electric system conforms to CEI norms</i> impianto elettrico a norme CEI	<i>control box</i> centralina
<i>electric requirements</i> caratteristiche elettriche	230/110V ac	50/60 Hz	0,70 A max	120 Va	IP 54	✓	<i>class II</i> classe II

WARRANTY

structure: 10 years

motors and controls: 2 years

undeformable foam: 5 years

heating: 1 year

GARANZIA

struttura: 10 anni

motori e comandi: 2 anni

gomma indeformabile: 5 anni

riscaldamento: 1 anno

REGULATIONS

All Equipment is  marked

Medical devices

Directive 93/42/CEE (Medical Devices Directive) and D. Lgs 24th February 1997,

n. 46 - medical device Class I (rule 12) annexe IX dir. 93/42/CEE

NORME

Tutte le attrezzature sono a marchio 

Dispositivi medici

Direttiva 93/42/CEE concernente i dispositivi medici e D. Lgs 24 Febbraio 1997,

n.46 - dispositivo medico di classe I (regola 12) secondo l'allegato IX dir.93/42/CEE